



An Orbia business.

Reel Return Guidelines

Why should I participate?

Dura-Line manufactures high-density polyethylene conduit and innerduct that is packaged and shipped on high-quality steel reels. Our steel reels are very durable and can be re-used multiple times.

Dura-Line is concerned about the environment and has developed a program to recycle these steel reels.

In one year alone, Dura-Line recycled over 13 million pounds of steel reels, saving both the natural resources and the energy that would have been required to produce new reels.

Help us in this effort to save energy and the environment by recycling your used conduit shipping reels.

Where do I start?

Contact the Dura-Line Reel Return Coordinator to obtain a Return Authorization number (RA#).

All returns require an RA# in order for the reels to be accepted at the Dura-Line facility and tracked to receive a potential rebate.

Are my reels acceptable?

Dura-Line accepts steel reels, with a single or double arbor plate, 7-10 spoke construction, and bolt-in-place staves.



Tolerance of Acceptable Reels

All reels will be inspected upon return and must meet the following tolerances:



Flanges

Flanges must be round and able to roll freely. Dents or kinks in the round shape cannot exceed $\frac{1}{2}$ ". For an easy measuring gauge, compare the reel in question to a reel in original shape.



Staves

Staves should be straight, without significant bends or kinks. Use a straight edge, level, or the Dura-Line Grading Tool to gauge the staves are "straight" with no more than $\frac{1}{2}$ " deviation from the straight edge.



Arbor Holes

Arbor holes need to be smooth, free from divits or rugged spots, and within the $\frac{1}{4}$ " of the original $3\frac{1}{4}$ " footprint.

What Reels are Not Acceptable?

Reels with flattened or bent flange, cracked weld, wooden staves are all unacceptable.

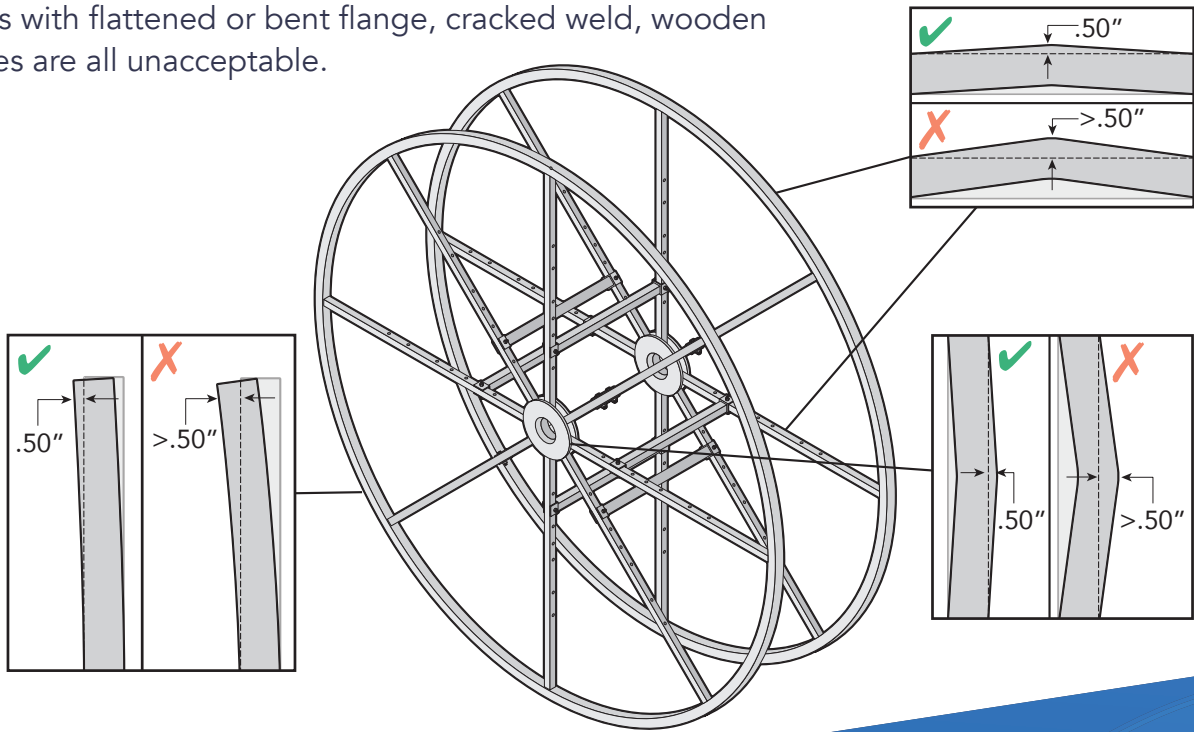

Bent Spoke



Flattened Flange



Cracked Weld



Wooden Staves

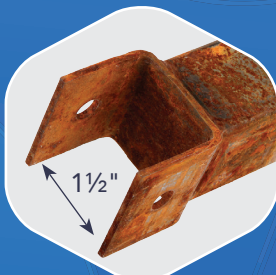

$1\frac{1}{2}''$ Unacceptable



L-Bracket



Exposed Bead Welding
Not Acceptable



L-Bracket Flange with
Punch-out Holes



How do I break down and ship reels to return?

If the reels are in good condition and have met the acceptable guidelines, they can be returned for rebate.



Scan to view video or visit
<https://qrco.de/bdkD7v>

Important considerations:

Make sure to obtain a Return Authorization (RA#) prior to returning reels to any Dura-Line facility

Before disassembling reels, use at least a 2-person team wearing appropriate safety equipment.

Reels can be easily disassembled offering the following advantages:

- 1 Disassembled reels require less storage space
- 2 Reduce return freight costs by maximizing space on the truck
- 3 Lower freight cost delivers a higher rebate value

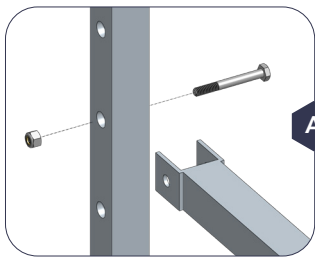

1 Steel Reel Disassembly

The reels are easily disassembled by removing the two bolts that connect each stave to the flange (A).

Once the staves are removed the flanges can be stacked no more than 30 flanges per stack and must be banded and secured with (4) four $\frac{3}{4}$ " steel bands (B).

Once the flanges are banded to the pallet, they can be stacked two (2) high for transportation (C).

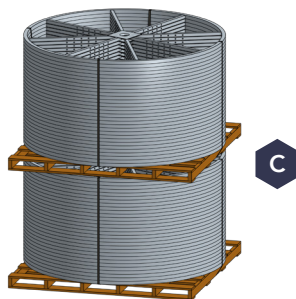
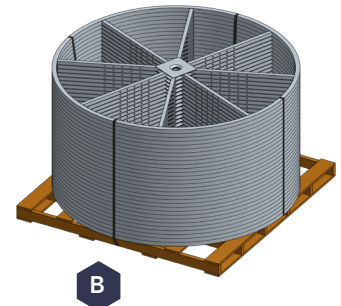

2 Packaging and Securing Reels for Return

Stack the staves in single rows across either a pallet or two (2) 4x4 wood beams.

Stack the staves in alternating directions in each row, taking care the entire stack is no higher than 3 feet tall.

Secure the stack with steel bands.

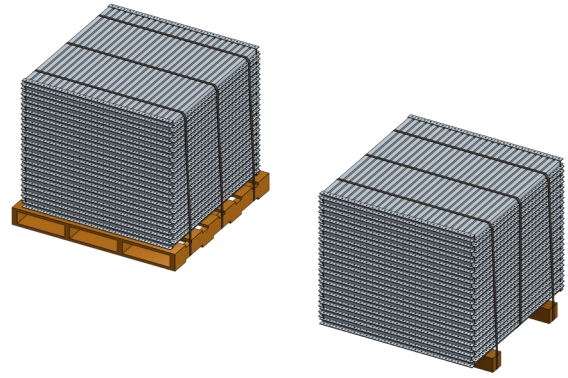

3 Flanges >114" Diameter

Flanges 114" and larger must be shipped standing upright.

When shipping flanges upright, due to clearance requirements, they will need to be loaded onto a lowboy, drop-deck or step-deck type truck.

The lower bed height will allow the reels to be shipped in the upright position without exceeding allowable height restrictions.

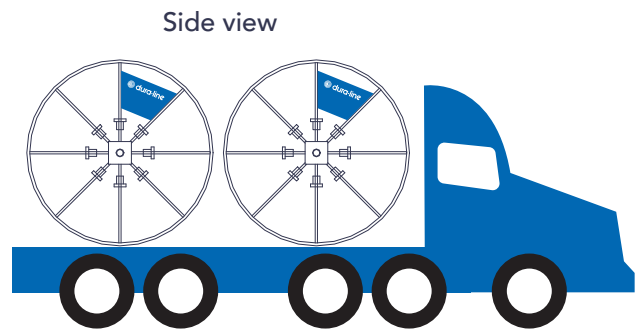

Note: Dura-Line does not accept reels in an enclosed type truck or van.

Which Dura-Line facilities accept Reel Returns?

Georgia

995 Waco Mill Road
Tennille, GA 31089

Missouri

1299 Industrial Park Road
Mountain Grove, MO 65711

Texas

2406 North I-35
Gainesville, TX 76240

Ohio

860 Garden Street
Elyria, OH 44035

Wyoming

6790 Santa Fe Circle
Evansville, WY 82636

Utah

80 East Union Avenue
North Salt Lake City, UT 84054

Canada - East

2-1964 Muskoka Beach Rd.
Gravenhurst, ON P1P 1R1

Canada - West

220 Carnegie Dr.
St. Albert, AB T8N 5A7