

PRODUCT SOLUTIONS GUIDE

HDPE STICKS

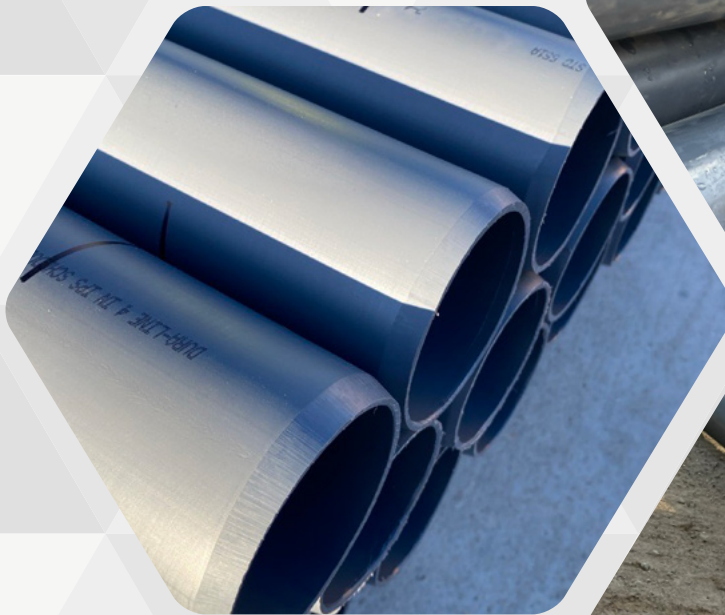

CONTENTS

HDPE STICKS.....	3
ACCESSORIES.....	4
PACKAGING, SHIPPING, AND HANDLING	6
INSTALLATION PHOTOS	12
COUPLING.....	16
SWEEPS AND BENDS	25
KEY CONSIDERATIONS FOR INSTALLATIONS	27
PROOFING	34
DURA-LINE ACADEMY.....	37

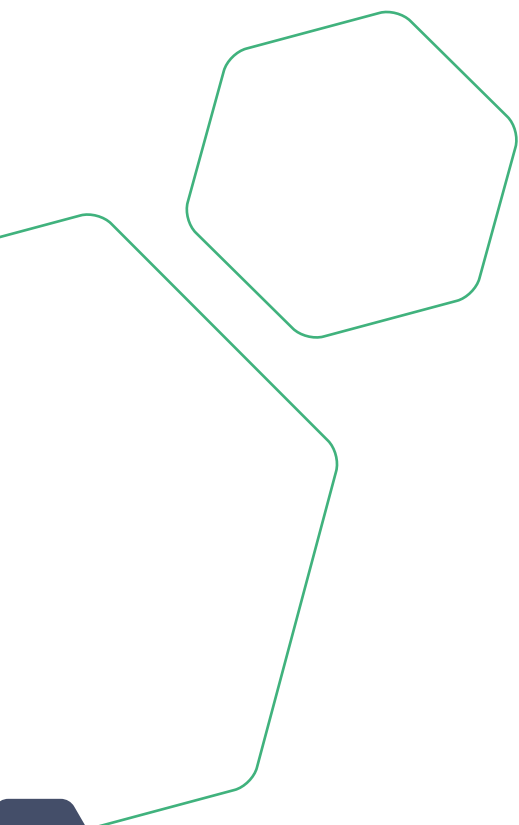

HDPE STICKS

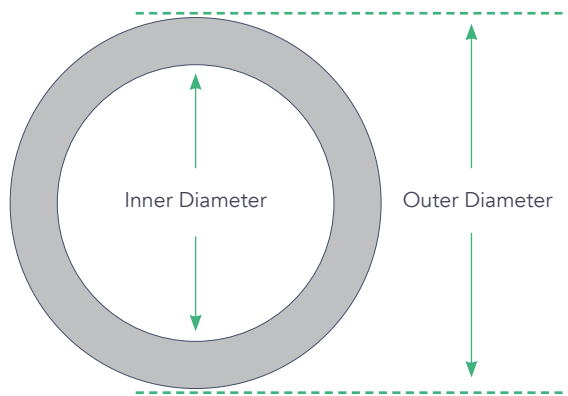
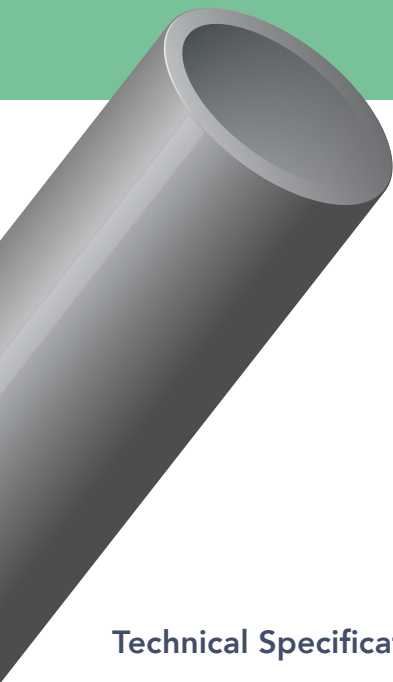

Standard Specification:

20' and 40' sticks in gray

8" only available in black

Options:

UL-listed conduit

SILICORE® ULF permanently lubricated inner lining (2" – 6")

Alternative colors: red, black, or black with red stripes (2" – 6")

Technical Specifications

MATERIAL DESCRIPTION	NOM OD (IN)	OD TOLERANCE +/-	MIN WALL (IN)	WALL TOLERANCE +	AVG ID (IN)	MIN ID (IN)	WEIGHT (LB/FT)	BEND RADIUS SUP (IN)	BEND RADIUS UNSUP (IN)	SWPS (LBS)
2" SCH 40	2.375	0.012	0.154	0.020	2.047	2.027	0.469	24	48	2,579
2" SCH 80	2.375	0.012	0.218	0.026	1.913	1.887	0.641	24	48	2,545
2 1/2" SCH 40	2.875	0.014	0.203	0.024	2.445	2.421	0.740	29	58	4,090
2 1/2" SCH 80	2.875	0.014	0.276	0.033	2.290	2.257	0.978	29	58	5,409
3" SCH 40	3.500	0.018	0.216	0.026	3.042	3.016	0.969	39	78	5,348
3" SCH 80	3.500	0.018	0.300	0.036	2.864	2.828	1.310	39	78	7,238
4" SCH 40	4.500	0.023	0.237	0.028	3.998	3.970	1.380	50	100	7,618
4" SCH 80	4.500	0.023	0.337	0.040	3.786	3.746	1.914	50	100	10,578
5" SCH 40	5.563	0.028	0.258	0.031	5.016	4.985	1.872	61	122	10,320
5" SCH 80	5.563	0.028	0.375	0.045	4.768	4.723	2.657	61	122	14,669
6" SCH 40	6.625	0.033	0.280	0.034	6.031	5.997	2.432	73	146	13,395
6" SCH 80	6.625	0.033	0.432	0.052	5.709	5.657	3.656	73	146	20,172
8" SCH 40	8.625	0.043	0.322	0.039	7.942	7.903	3.661	155	233	20,158

Unsupported Bend Radius guidelines should be followed during the installation process. The Supported Bend Radius are post-installation measurements.

†Safe working pull strength is calculated at 80% of tensile or breaking strength.

1. Bend Radius

2" through 2 1/2"
3" through 6"
8"

Supported Bend Radius 10 times the OD
Supported Bend Radius 11 times the OD
Supported Bend Radius 18 times the OD

Unsupported Bend Radius 20 times the OD
Unsupported Bend Radius 22 times the OD
Unsupported Bend Radius 27 times the OD

2. During cable placement, large sweeping bends are recommended over tighter bends.

3. SWPS (Safe Working Pull Strength) is calculated using a 25% safety factor with the minimum resin tensile strength of 3,000 psi, the average OD and average wall thickness.

ACCESSORIES

Couplers and Plugs

ACCESSORY	UL-LISTED (Y/N)	PART #
3" ConduitConnect™		20097517
4" ConduitConnect	ETL	20096550
6" ConduitConnect	ETL	20096882
2" Shur-Lock II	ETL	20000123
2 1/2" Shur-Lock II	ETL	20000172
3" Shur-Lock II	ETL	20000173
4" Shur-Lock II	ETL	20000245
5" Shur-Lock II	ETL	20000254
6" Shur-Lock II	ETL	20000256
2" NS Shur-Lock II	ETL	20000237
2 1/2" NS Shur-Lock II	ETL	20000238
3" NS Shur-Lock II	ETL	20000239
4" NS Shur-Lock II	ETL	20000260
5" NS Shur-Lock II	ETL	20001531
6" NS Shur-Lock II	ETL	20000261
2" Redi-Lock		20005477
2 1/2" Redi-Lock		20005478
4" Redi-Lock		20005480
5" Redi-Lock		20005481
6" Redi-Lock		20005482
8" E-LOC		20003118
2" Expansion Plug		20001870
2 1/2" Expansion Plug		20003426
3" Expansion Plug		20001764
4" SDR Expansion Plug		20005808
5" Expansion Plug		20001766
6" Expansion Plug		20001763



Left to right, from top:

- ConduitConnect™
- Shur-Lock II
- Redi-Lock
- E-LOC
- Expansion Plug
- HDPE Sweeps
- Bull-Line® Pull Tape

ACCESSORIES

HDPE Sweeps

SIZE/WALL TYPE	UL-LISTED (Y/N)	ANGLE (DEGREES)	RADIUS (IN)	PALLET QTY (EA)	MOQ (EA)	COLOR	PART #
2" SCH 40		22.5	36	150	25	Black	20096032
2" SCH 40	Ⓛ	45	36	150	25	Black	20094686
2" SCH 40	Ⓛ	90	36	150	25	Black	20094685
2" SCH 40	Ⓛ	90	36	150	25	Gray	20094904
2 1/2" SCH 40		90	36	150	25	Gray	20094906
3" SCH 40		22.5	36	150	25	Black	20096033
3" SCH 40	Ⓛ	45	36	75	25	Black	20094688
3" SCH 40	Ⓛ	90	36	75	25	Black	20094687
4" SCH 40		22.5	36	60	30	Black	20094770
4" SCH 40	Ⓛ	45	36	60	30	Black	20005885
4" SCH 40		90	24	50	25	Black	20096992
4" SCH 40	Ⓛ	90	36	50	25	Black	20005886
4" SCH 40	Ⓛ	90	36	50	25	Gray	20094938
4" SCH 40		90	48	50	25	Black	20096993
4" SCH 80		22.5	36	60	30	Black	20096311
4" SCH 80		45	36	60	30	Black	20096034
4" SCH 80		90	36	50	25	Black	20096035
6" SCH 40		45	36	25	25	Black	20096497
6" SCH 40		90	36	10	10	Black	20096498
6" SCH 40		90	48	20	20	Black	20096994
6" SCH 40		90	60	20	20	Black	20096995
6" SCH 80		45	36	25	25	Black	20096500
6" SCH 80		90	36	10	10	Black	20096501

Bull-Line® Pull Tape

DESCRIPTION	LENGTH	REEL SIZE	TYPE	PART #
WP18 tensile: 1,800lb width: 5/8" (16mm) weight/ft: 0.0105lb	3000'	13"	Plastic	20000068
	5000'	16"	Plastic	20000070
	10000'	18"	Plastic	20000389
WP25 tensile: 2,500lb width: 3/4" (19mm) weight/ft: 0.0142lb	3000'	14"	Plastic	20000077
	5000'	16"	Plastic	20000080
	10000'	24"	Wood	20000074

PACKAGING, SHIPPING, AND HANDLING

Packaging Information

SIZE	2"		2 1/2"		3"		4"	
Stick Length (ft.)	20	40	20	40	20	40	20	40
Sticks per bundle	98	98	78	78	50	50	29	29
Bundles per truck	24	12	28	14	28	14	28	14
Sticks per truck†	2,352	1,176	2,184	1,092	1,400	700	812	406
Feet per truck†	47,040	47,040	43,680	43,680	28,000	28,000	16,240	16,240
Wall Type	SCH 40		SCH 40		SCH 40		SCH 40	
Stick Length (ft.)	20	40	20	40	20	40	20	40
Weight per foot (lb.)	0.47	0.47	0.74	0.74	0.969	0.969	1.38	1.38
Weight per stick (lb.)	9.40	18.80	14.8	29.6	19.38	38.76	28	55.2
Weight per bundle (lb.)	921	1,842	1,154	2,309	969	1,938	800	1,601
Weight per truck (lb.)	22,109	22,109	32,323	32,323	27,132	27,132	22,411	22,411
Wall Type	SCH 80		SCH 80		SCH 80		SCH 80	
Stick Length (ft.)	20	40	20	40	20	40	20	40
Weight per foot (lb.)	0.64	0.64	0.978	0.978	1.31	1.31	1.914	1.914
Weight per stick (lb.)	12.80	25.60	19.56	39.12	26.2	52.4	38.28	76.56
Weight per bundle (lb.)	1,254	2,509	1,526	3,051	1,310	2,620	1,110	2,220
Weight per truck (lb.)	30,106	30,106	42,719	42,719	36,680	36,680	31,083	31,083

SIZE	5"		6"		8"	
Stick Length (ft.)	20	40	20	40	20	40
Sticks per bundle	15	15	13	13	14	14
Bundles per truck	28	14	28	14	16	8
Sticks per truck	420	210	364	182	224	112
Feet per truck	8,400	8,400	7,280	7,280	7,280	4,480
Wall Type	SCH 40		SCH 40		SCH 40	
Stick Length (ft.)	20	40	20	40	20	40
Weight per foot (lb.)	1.872	1.872	2.432	2.432	3.661	3.661
Weight per stick (lb.)	37.44	74.88	48.64	97.28	73.22	146.44
Weight per bundle (lb.)	562	1,123	632	1,265	1,025	2,050
Weight per truck (lb.)	15,725	15,725	17,705	17,705	16,401	16,401
Wall Type	SCH 80		SCH 80			
Stick Length (ft.)	20	40	20	40		
Weight per foot (lb.)	2.657	2.657	3.656	3.656		
Weight per stick (lb.)	53.14	106.28	73.12	146.24		
Weight per bundle (lb.)	797	1,594	951	1,901		
Weight per truck (lb.)	22,319	22,319	26,616	26,616		

Note, total quantity and weight per truck may vary by shipping location and vehicle type.

PACKAGING, SHIPPING, AND HANDLING

Bundle Packaging

Each bundle is held together by a frame of wooden boards and bands. Boards are placed 36" from either end of the bundle and 7' intervals thereafter. For 20' sticks, this means a total of three boards, and for 40' sticks, six boards with an additional band (no board) in the center of the bundle. For both 20' and 40' bundles, a band (no board) is also placed 15' from the end of each bundle. The drawings below are based on bundles of 4" HDPE sticks.

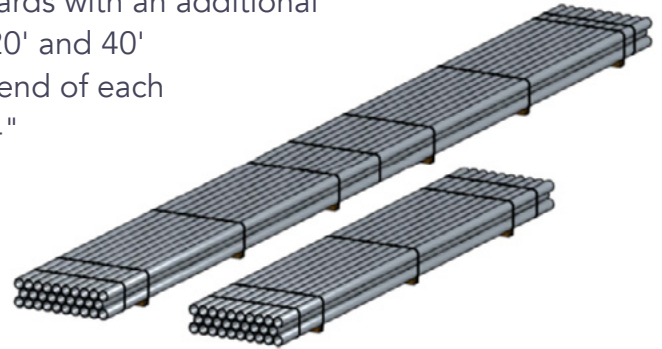
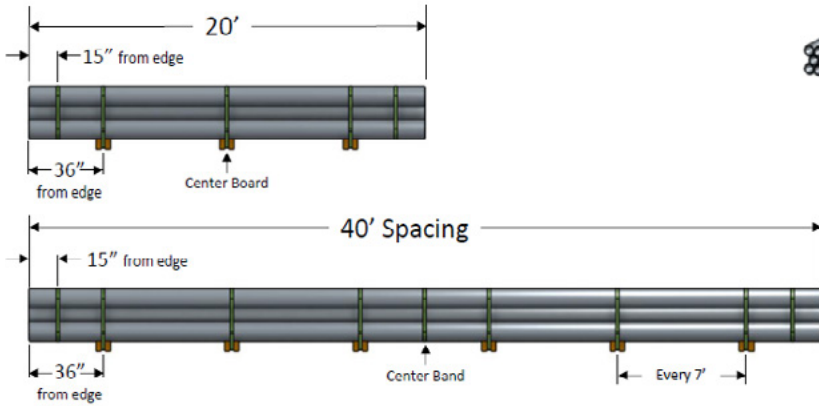

Quality

Our conduit production processes employ high levels of scrutiny and quality control throughout, meaning you can count on full traceability through a product's entire operational lifetime. All our US facilities are certified according to ISO 9001, ISO 45001, and TL 9000 and UL-listed products are certified via an independent listing agency.



Transportation

Sticks are shipped by flat-bed truck. Wherever possible, each truckload is made up of the maximum number of bundles for a given stick size, as detailed in the table on page 6.

PACKAGING, SHIPPING, AND HANDLING

More Details

- ▶ Bundles are loaded onto the truck bed in a staggered manner so that the frames do not rest on one another, as this can cause the truck's maximum load height to be exceeded.
- ▶ Bundles are secured with heavy-duty straps which run vertically over the stack, some over the top of the bundles and some lower down.
- ▶ Straps are spaced evenly along the length of the trailer, ensuring that each section of the load is held down securely.
- ▶ Straps are tensioned and anchored to the sides of the flatbed trailer, likely using ratchet mechanisms to maintain tightness and prevent movement during transit.
- ▶ The strapping method is designed to keep the bundles from shifting or rolling, which is crucial for safety and compliance with transportation regulations.



PACKAGING, SHIPPING, AND HANDLING

Inspection of Shipments Upon Arrival

It is recommended that the following checks are completed to ensure all materials are intact and as ordered when received:

1. Visual Inspection

Check each bundle and stick for visible damage, such as strap deformation. Inspect the ends of the sticks for chips. Confirm that all protective packaging and banding straps are intact and have not been compromised during shipping.

2. Quantity and Specification Verification

Cross-check the delivered quantities against the shipping manifest and order documentation. Ensure that the correct stick sizes, wall types, and any accessories (such as couplers or plugs) are present and match the order.

3. Handling and Storage Readiness

Verify that the site has adequate space and proper support for unloading and storing the sticks. Ensure that handling equipment (such as fork trucks with wide forks or spreader bars) is available to prevent damage during unloading. If any HDPE sticks or accessories are found to be damaged or do not meet order specifications upon delivery, document with photos and detailed notes, and report to your Dura-Line representative immediately and retain all original packaging and documentation.

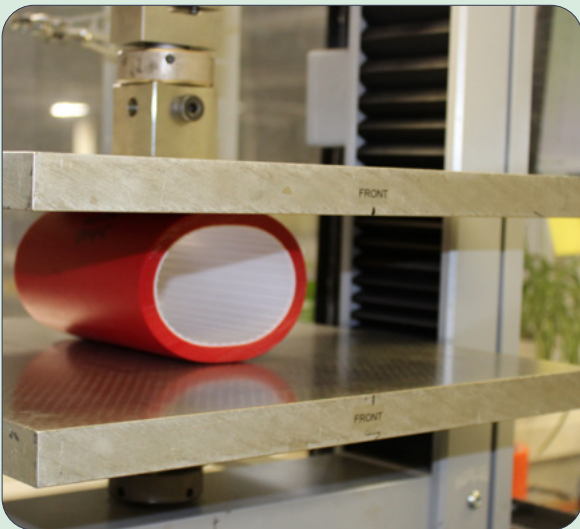

HDPE conduit undergoing compression testing

A Note on Deformities

HDPE sticks are known for their excellent flexibility, toughness, and resistance to impact and chemicals. One notable property is their shape memory – HDPE can return to its original round shape after being deformed, especially when exposed to alternating hot and cold cycles.

This is due to the polymer's ability to relax internal stresses and "heal" minor deformations over time. This property makes HDPE sticks highly suitable for applications where temporary deformation may occur during handling, transport, or installation, as they can recover without compromising performance.

PACKAGING, SHIPPING, AND HANDLING

Loading and Unloading

HDPE sticks require attentive handling when loading onto and unloading off a truck as recommended procedures differ from PVC conduit, with which installers may be more familiar.

Specifically, due to HDPE's inherent flexibility, long stick lengths can bend or sag if not properly supported. To prevent damage or injury during unloading, it is recommended to use wide forks (i.e., spreader bars) or dual-fork trucks to distribute weight evenly and maintain conduit integrity.

20' Sticks: use single-fork truck support

A single fork truck can be used for loading and unloading of 20' HDPE sticks. The key is to use wide forks or a spreader bar to distribute the weight evenly across the length of the bundle.

40' sticks: use dual-fork truck support

For 40-foot HDPE sticks, the recommended approach is to use two fork trucks, each positioned approximately one-quarter of the length in from each end of the bundle (i.e., about 10 feet from each end for a 40-foot stick). This method ensures the weight of the bundle is distributed across its entire length, minimizing sag and preventing damage.



Single-fork truck lifting a bundle of 20' HDPE sticks



Telehandler lifting a bundle of 20' HDPE sticks



Dual-fork lifting a bundle of 40' HDPE sticks

PACKAGING, SHIPPING, AND HANDLING

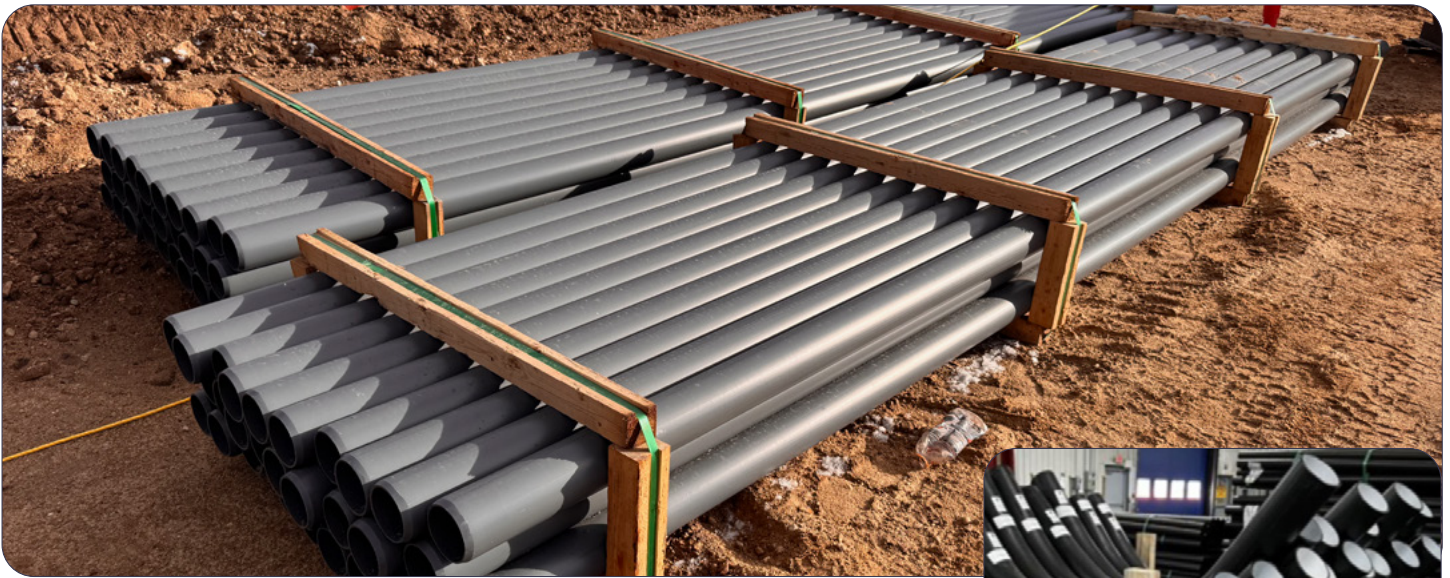

HDPE sticks staged near trench

Storage Onsite

Recommendations for storing HDPE products on-site before installation, ensuring protection from weather and damage:

- ▶ When storing HDPE products at an outdoor jobsite, select a flat, stable area that is free from sharp objects or debris that could damage the conduit.
- ▶ Bundles and sweeps should be kept off the ground using pallets or supports to prevent direct contact with soil and standing water.
- ▶ For more efficient installations, stage the conduit as close as safely possible to the point of use. This reduces handling, minimizes risk of damage during movement, and helps crews maintain a steady workflow.
- ▶ Ensure there is enough space for equipment to access and move stick bundles without causing congestion or safety hazards. Always follow recommended loading and unloading procedures, such as using wide forks or spreader bars, as detailed on page 10 of this document.
- ▶ Products should be installed per the infrastructure owner's recommended processes and procedures within 2 years of the manufacturing date.

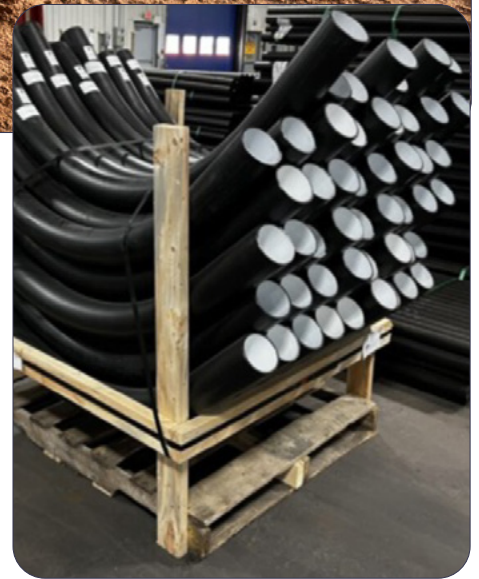

HDPE sweeps on a pallet



Bundle of sticks on supports

INSTALLATION PHOTOS

In this section, you will find photos documenting key aspects of HDPE stick installations. Always follow the infrastructure owner's recommended processes and procedures for trenching (or alternative underground installation methods), duct run construction, and backfill. While these photos depict duct bank installations, the processes shown would be largely the same for single-duct runs, albeit on a smaller scale.

Trenching

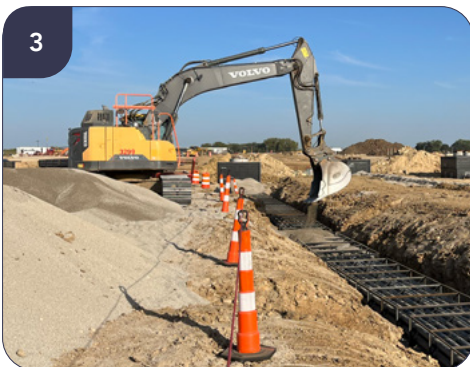

Photo Descriptions:

1. Straight run of 40' sticks, built in trench
2. 20' sections built off site and lowered into trench
3. Backhoe pouring backfill material into trench
4. Backfill material
5. Backfill material around ducts
6. Concrete pouring and curing

INSTALLATION PHOTOS

Bends Without Sweeps



When Should I Use a Sweep?

When building with HDPE sticks, Dura-Line typically recommends using a sweep for bends of 45 degrees or more. See page 26 for more information.

Photo Descriptions:

1. Bend accommodated without a sweep
2. & 3. Gradient accommodated without a sweep

INSTALLATION PHOTOS

Coupling



Photo Descriptions:

1. Installing ConduitConnect™ coupler with rubber mallet and wooden block
2. Driver-style coupling aid
3. Anvil-style coupling aid securing ConduitConnect couplers
4. Lubricated ConduitConnect coupler
5. Duct bank with ConduitConnect couplers

INSTALLATION PHOTOS

Vaults



Photo Descriptions:

1. Gradual bend into vault without sweeps
2. Transition out of vault with ConduitConnect couplers
3. Vault interior with expansion plugs



COUPLING

Conduit Preparation

Depending on the installation scenario (i.e., installation of new sticks or replacement of a damaged section) and chosen/required coupling method (mechanical or fusion), it may be necessary to cut, debur, and bevel conduit ends prior to coupling. The following types of tools are recommended for these procedures:

Cutting: use a hand-held, battery-powered saw to make a clean, straight cut.

Example: Milwaukee SAWZALL



Deburring: use a simple pipe reamer and deburring tool, like the one shown, to remove any debris from the conduit end created during cutting.

Example: Milwaukee Reaming Pen Deburring Tool



Beveling: make coupler installation easier and more secure by beveling the conduit ends with a portable, battery-powered beveler. Note, beveling of HDPE is not typically necessary for fusion coupling.

Example: Reed Bevel Boss®



Photo Descriptions:

1. Setup for field cutting and beveling
2. Beveled sticks

COUPLING

Mechanical Coupling

Dura-Line offers a range of mechanical couplers suitable for use with HDPE sticks.

ConduitConnect™ – preferred coupling solution for duct banks

- ▶ Specifically designed for duct banks with a high-strength HDPE body
- ▶ Air- and water-tight with a pre-lubricated gasket for easy installation
- ▶ ETL-listed to UL 541B
- ▶ No special tools required



PRODUCT DESCRIPTION	NOM OD (IN)	DUCT OD WORKING RANGE (IN)	HEIGHT (IN)	PACKAGING	DURA-LINE PART #
3" ConduitConnect	3.500"	3.480" - 3.520"	8.25"	Each	20097517
4" ConduitConnect	4.500"	4.480" - 4.520"	10.00"	Each	20096550
6" ConduitConnect	6.625"	6.605" - 6.645"	13.00"	Each	20096882

Shur-Lock II – a versatile alternative

- ▶ UL-listed and ideal for coupling HDPE to other conduit materials
- ▶ Stainless steel band clamps and locking ring for hand-tightening
- ▶ No-stop (NS) version available for confined areas or repairs



PRODUCT DESCRIPTION	NOM OD (IN)	DUCT OD WORKING RANGE (IN)	HEIGHT (IN)	PACKAGING	DURA-LINE PART #
2" Shur-Lock II	2.375"	2.355" - 2.395"	5.70	Case of 10	20000123
2 1/2" Shur-Lock II	2.875"	2.855" - 2.895"	9.25	Case of 6	20000172
3" Shur-Lock II	3.500"	3.480" - 3.520"	10.75	Case of 6	20000173
4" Shur-Lock II	4.500"	4.480" - 4.520"	12.00	Case of 4	20000245
5" Shur-Lock II	5.563"	5.543" - 5.583"	14.25	Case of 2	20000254
6" Shur-Lock II	6.625"	6.605" - 6.645"	14.25	Case of 2	20000256
2" NS Shur-Lock II	2.375"	2.355" - 2.395"	5.70	Case of 10	20000237
2 1/2" NS Shur-Lock II	2.875"	2.855" - 2.895"	9.25	Case of 6	20000238
3" NS Shur-Lock II	3.500"	3.480" - 3.520"	10.75	Case of 6	20000239
4" NS Shur-Lock II	4.500"	4.480" - 4.520"	12.00	Case of 4	20000260
5" NS Shur-Lock II	5.563"	5.543" - 5.583"	14.25	Case of 2	20001531
6" NS Shur-Lock II	6.625"	6.605" - 6.645"	14.25	Case of 2	20000261

COUPLING

Redi-Lock - HDPE to HDPE coupling for buried applications

- ▶ For coupling HDPE to HDPE only
- ▶ High-strength molded plastic body
- ▶ Stainless steel band clamps and locking ring for hand-tightening



PRODUCT DESCRIPTION	NOM OD	PULL-OUT STRENGTH (LBS)	MAX PRESSURE (PSI)	PACKAGING	DURA-LINE PART #
2" Redi-Lock	2.375"	700	70	Case of 10	20005477
2 1/2" Redi-Lock	2.875"	750	55	Case of 6	20005478
4" Redi-Lock	4.500"	950	40	Case of 4	20005480
5" Redi-Lock	5.563"	1,000	40	Case of 2	20005481
6" Redi-Lock	6.625"	1,000	15	Case of 2	20005482

E-LOC - for coupling 8" HDPE sticks

- ▶ Economical push-on coupler with a molded rubber gripping insert
- ▶ Primary solution for coupling 8" sticks
- ▶ Couples HDPE, PVC, Fiberglass, and metal conduit

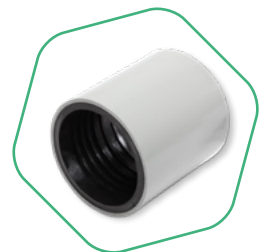

PRODUCT DESCRIPTION	DUCT OD WORKING RANGE	LENGTH	PACKAGING	SHIP WEIGHT (LBS)	DURA-LINE PART #
8" SDR E-LOC Coupler	8.582" - 8.668"	8"	EA	10.70	20003118

Coupler Choice

The optimal coupler choice is determined by the material of the conduits or sweeps you are connecting:

SCENARIO	PREFERRED COUPLER	ALTERNATIVE COUPLERS
HDPE to HDPE	ConduitConnect™	Shur-Lock II (inc. NS), Redi-Lock, E-LOC (8" only)
HDPE to PVC	ConduitConnect	Shur-Lock II (inc. NS), Redi-Lock, E-LOC (8" only)
HDPE to Fiberglass	Shur-Lock II (inc. NS)	E-LOC (8" only)
HDPE to Steel	Shur-Lock II (inc. NS)	E-LOC (8" only)

COUPLING

ConduitConnect™ Installation

Dura-Line's ConduitConnect coupler is the preferred solution for duct bank installations built with HDPE sticks. The coupler has a high-strength HDPE body ideal for direct-burial, is air- and watertight with a pre-lubricated gasket, and can be installed quickly and easily by hand without special tools.

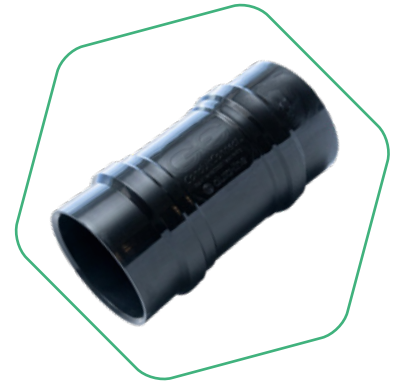

- ▶ These installation steps would be the same for joining:
 - HDPE conduit to HDPE (conduit or sweeps)
 - HDPE conduit to PVC conduit
- ▶ While not required, the ConduitConnect coupler's O-ring can be lubricated to make installation easier, with silicone-based lubricants recommended.

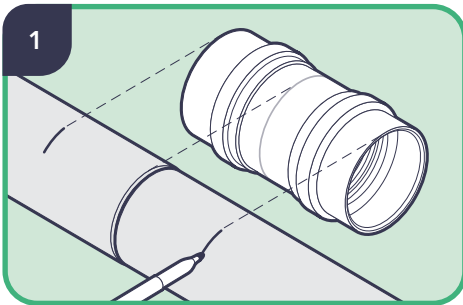

Step 1: Align both ducts at the center of the coupler and mark ends.

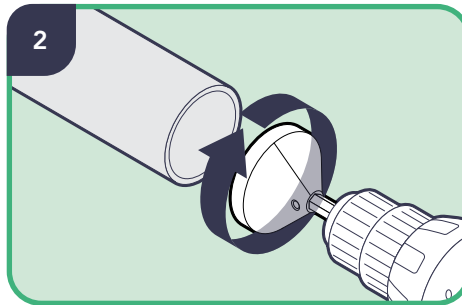

Step 2: Chamfer the end of each conduit for smoother insertion, unless using factory-beveled HDPE sticks.

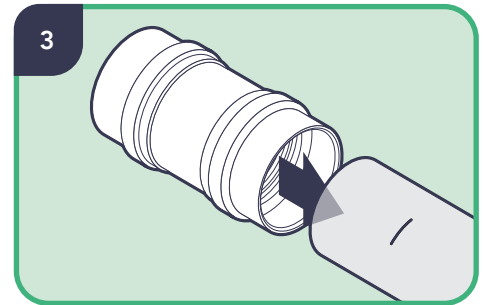

Step 3: Push the coupler onto the conduit.

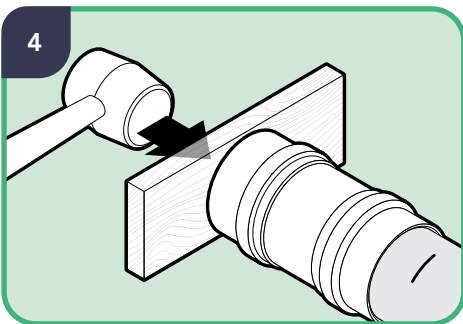

Step 4: If the coupler cannot be pushed to the center stop by hand, use a rubber mallet and wooden block to ease the coupler to the marker line, ensuring a secure fit.

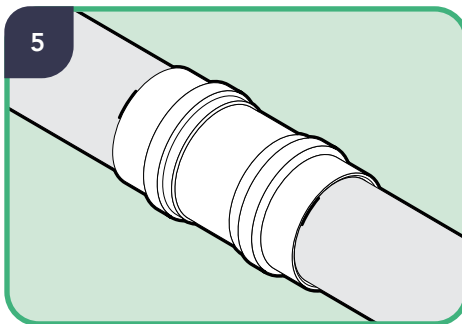

Step 5: Repeat the process for the second conduit, noting that the mallet and block may need to be used from the opposite end of the conduit.

COUPLING

Coupling Aids

While no special tools are specifically required to install ConduitConnect™, the following equipment may aid quick, secure installation.



Driver: can be used to seat a stick fully into the coupler when force must be applied to the end of the pipe and not the coupler itself.

Example: PVC Pipepounder



Anvil: can be used to fit ConduitConnect™ onto one end of an HDPE stick.

Example: KNOCK'ER-IN from Innisfree Tools

COUPLING

Shur-Lock II Installation

Note: Dura-Line's Shur-Lock II coupler provides a versatile alternative, ideal for joining HDPE to other conduit materials including PVC, fiberglass, and steel. It features stainless steel band clamps and a locking ring for hand-tightening. No-stop (NS) version available for confined areas, repairs, or building non-directional duct runs.

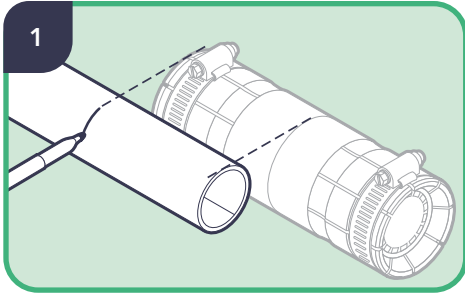

Step 1: Align both ducts at the center of the coupler and mark ends.

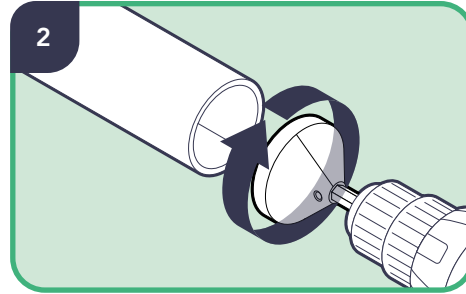

Step 2: Chamfer the end of the conduit for smoother insertion.

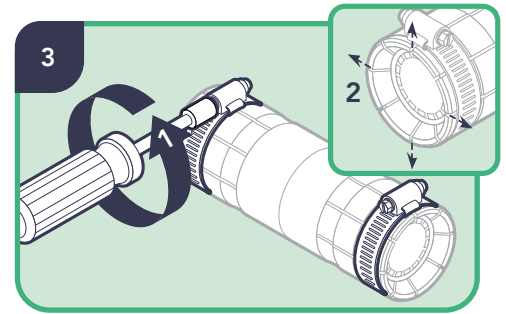

Step 3: Loosen the band clamps to allow spreading of the split segments on the end of the coupler during insertion.

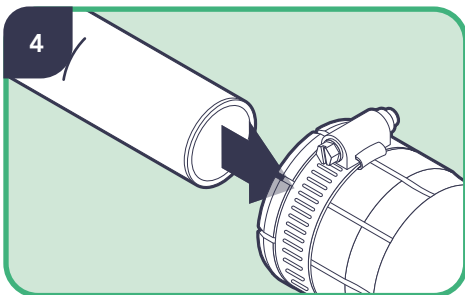

Step 4: Push conduit into coupler past the metal teeth to the mark to ensure O-ring is sealed around the duct.

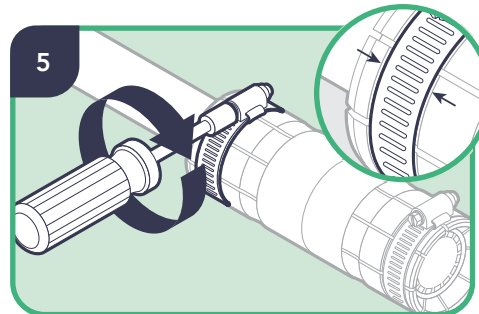

Step 5: Verify the band clamp is positioned in the groove and fully tighten it down with a 5/16" nut driver or cordless drill. Never use a drill to tighten the clamp.

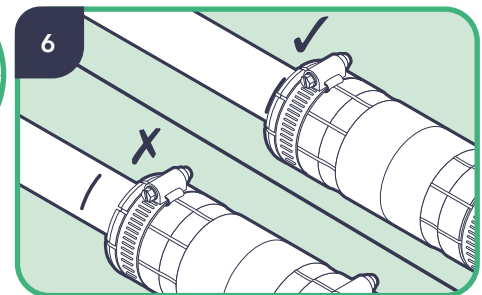

Step 6: Repeat process with second piece of duct.

COUPLING

NS Shur-Lock II Installation

Note: Dura-Line's standard Shur-Lock II coupler features an internal stop where the inner diameter is narrowed to ensure the conduit is seated properly within the coupler. In the NS Shur-Lock II, the stop is removed to allow the coupler to be pushed completely over one end of a conduit and pulled back over a joint and tightened, once both sections of conduit have been aligned. This is particularly useful where a section of duct needs to be repaired, or where a duct run has been built simultaneously from either end of the route and meeting in the middle to speed up the overall installation.

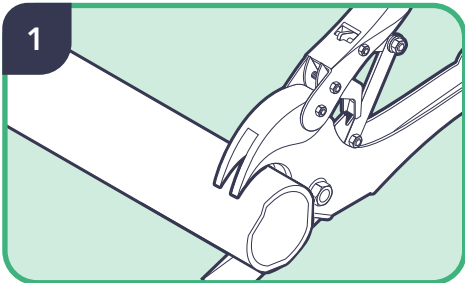

Step 1: Cut conduit flush with duct cutters.

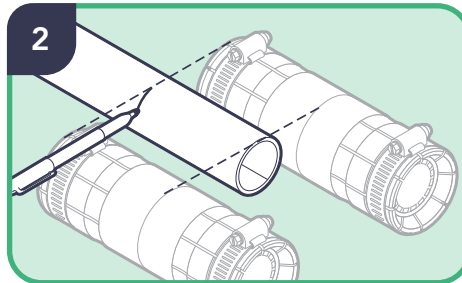

Step 2: Align both ducts at the center of the coupler and mark ends.

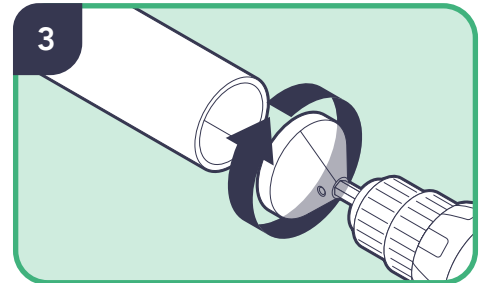

Step 3: Chamfer the end to allow for smooth insertion.

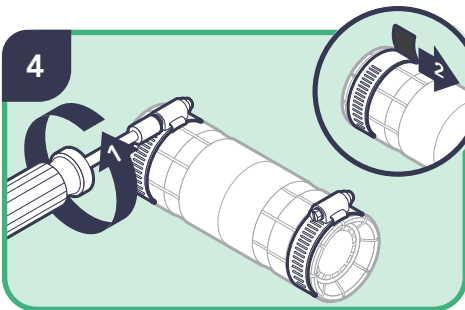

Step 4: Loosen band clamps and move them towards the middle of the coupler. Lightly tighten to hold in place during conduit insertion.

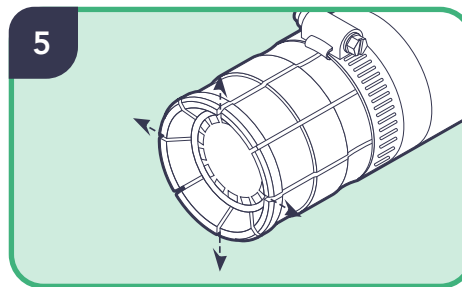

Step 5: Spread tabs on each end of the coupler so there is a 1/4" gap between tabs. For couplers 3" or larger, a spreader tool may be helpful.

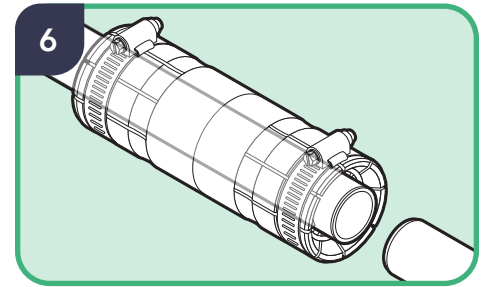

Step 6: Push conduit into coupler. To allow duct ends to align in tight spaces, coupler can be pushed completely on to one duct.

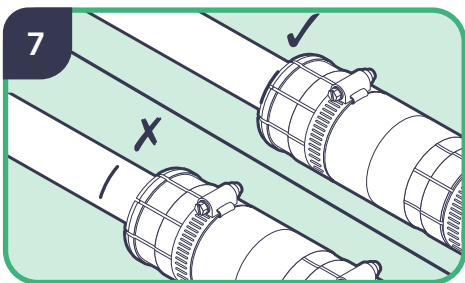

Step 7: Once duct ends are aligned, use the markings made in Step 1 to reposition the coupler centrally over the duct splice.

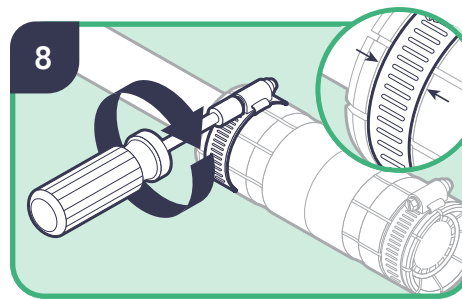

Step 8: Verify the band clamp is positioned in the groove and fully tighten it down with a 5/16" nut driver. Never use a drill to tighten clamp.

COUPLING

Redi-Lock Installation

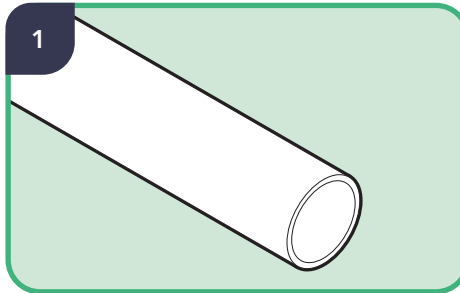

Step 1: Ensure your conduit has a clean, perpendicular cut.

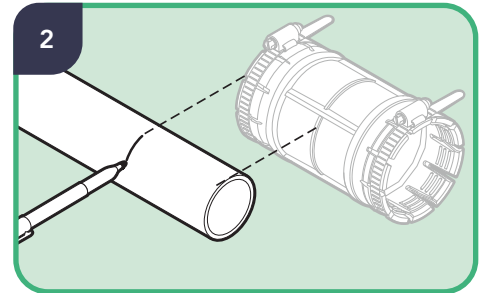

Step 2: Overlap ends of conduit. Place duct at center of coupler and mark end.

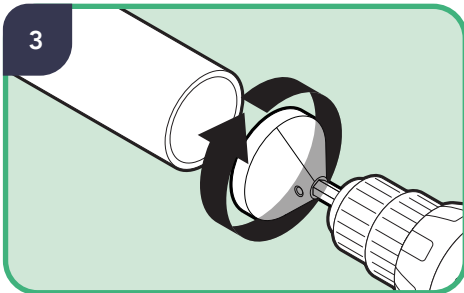

Step 3: Chamfer the leading edge of the conduit for smoother insertion.

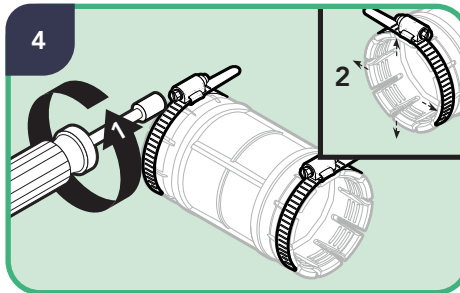

Step 4: Loosen the band clamps to allow spreading of the split segments on the end of the coupler during insertion.

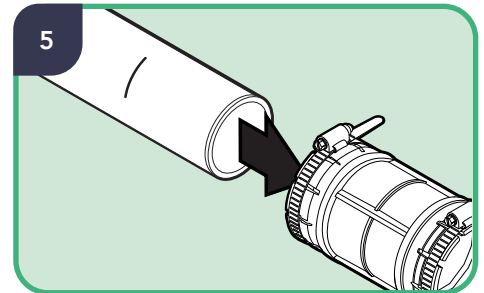

Step 5: Push conduit into the coupler past the grip ring and O-ring until it hits the center stop and the mark is aligned with the end of the coupler. This ensures the O-ring is seated properly.

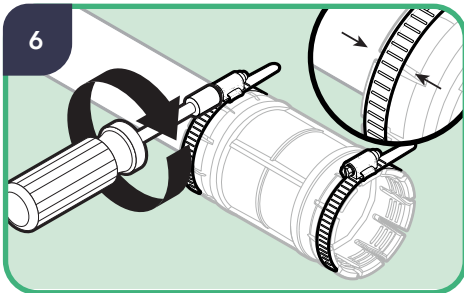

Step 6: Verify the band clamp is positioned in the groove and fully tighten it down.

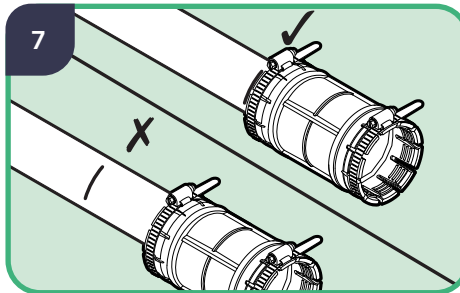

Step 7: Repeat process with second piece of duct.

COUPLING

Fusion Coupling

HDPE sticks can also be joined without a coupler via fusion coupling, which can create a joint as strong as, or stronger than, the conduit itself. The two most common forms are butt fusion and electrofusion coupling. Generally, it is not necessary to bevel or chamfer HDPE sticks prior to fusion coupling.

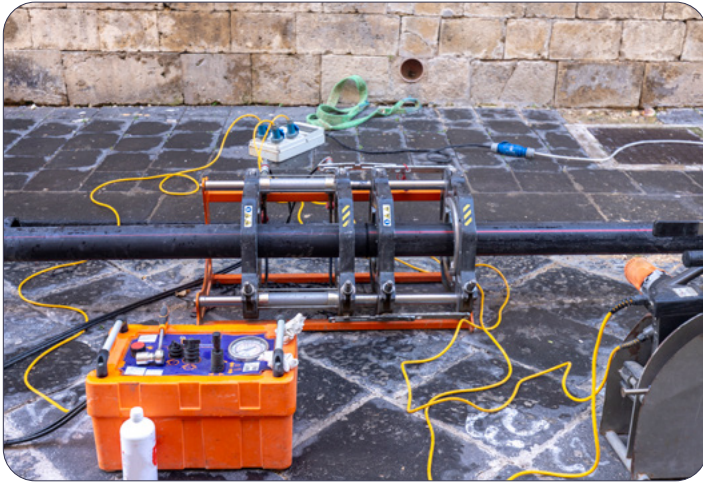

Butt Fusion

Two lengths of conduit are bonded with heat and no coupler. The conduit ends are cleaned, prepped and aligned with a clamp before heat is applied with a heating plate until the conduit ends are melted. Finally, the plate is removed and the joint is held in place until it cools and solidifies.



Electrofusion

Two lengths of conduit are joined with an automated, compact, electrically heated fitting which can reduce operator error and required working space, versus butt fusion. Another advantage over butt fusion is that this method does not create an inner bead at the joint, which can impair cable installation inside the conduit.

Note: photos on this page do not depict Dura-Line products

SWEEPS AND BENDS

Sweeps and Bends

When building with HDPE sticks, Dura-Line typically recommends using a sweep for bends of 45 degrees or more.

HDPE sticks are compatible with all common sweep types, including HDPE, PVC, fiberglass, and steel via an appropriate coupler:



SCENARIO	PREFERRED COUPLER	ALTERNATIVE COUPLERS
HDPE to HDPE	ConduitConnect™	Shur-Lock II (inc. NS), Redi-Lock, E-LOC (8" only)
HDPE to PVC	ConduitConnect	Shur-Lock II (inc. NS), Redi-Lock, E-LOC (8" only)
HDPE to Fiberglass	Shur-Lock II (inc. NS)	E-LOC (8" only)
HDPE to Steel	Shur-Lock II (inc. NS)	E-LOC (8" only)

Photos of preferred coupler options



HDPE to HDPE with ConduitConnect™



HDPE to PVC with ConduitConnect



HDPE to Fiberglass with Shur-Lock II



HDPE to Steel with Shur-Lock II

SWEEPS AND BENDS

When not to use a sweep

HDPE is inherently more flexible than other conduit materials such as PVC, fiberglass, and steel. This means it can often accommodate gradual changes in direction and elevation (of less than 45 degrees) without a preformed sweep, which can reduce overall sweep requirements and costs over the course of a project.



When making a bend without a sweep, be sure to:

- ▶ Make bends as long and gradual as possible to minimize tail load during cable pulling.
- ▶ Install any couplers outside of the bend to increase the strength of the joint.



KEY CONSIDERATIONS FOR INSTALLATIONS

Duct Routing Scenarios

The following illustrations detail some typical HDPE duct route deployment scenarios and the conduit, sweeps, and couplers that should be used in each. Refer to pg.30 for guidance on scheduling backfilling and/or concrete encasement, to mitigate the potential impact of thermal expansion and contraction.

SCENARIO 1: Typical directional build from vault to vault

- ▶ Transition out of Vault A made with ConduitConnect™ coupler
- ▶ Transition into Vault B made with NS Shur-Lock II coupler for ease of installation between two sections of conduit

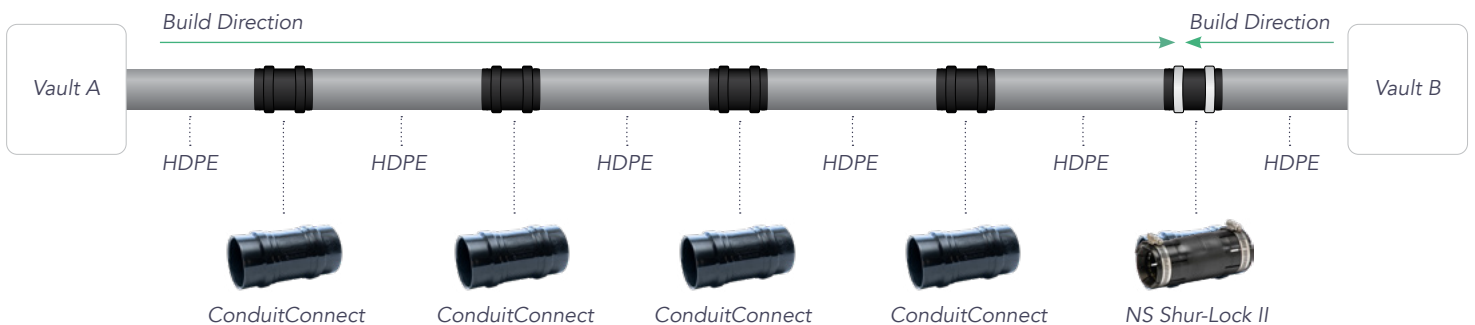

SCENARIO 2: Non-directional build from either vault, meeting in the middle

- ▶ Transitions in and out of each vault made with ConduitConnect couplers
- ▶ Central connection made with NS Shur-Lock II coupler for ease of installation in middle of run

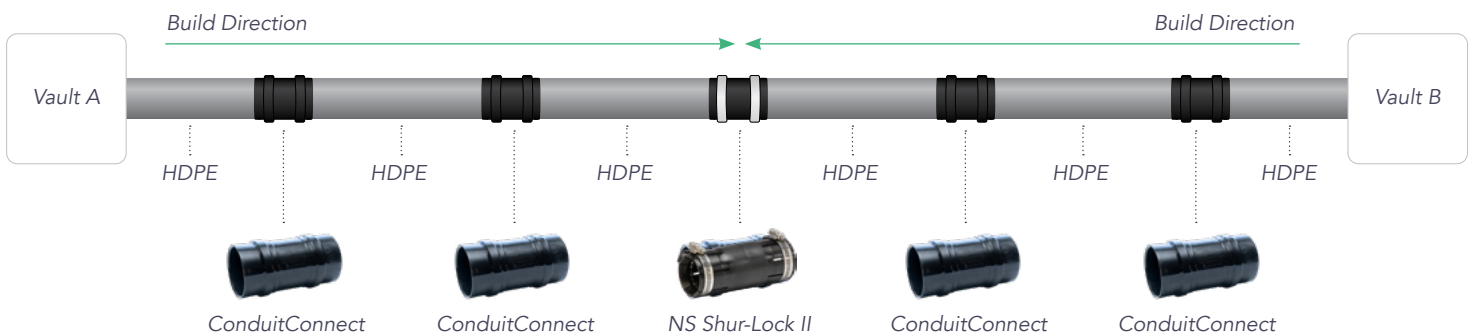

KEY CONSIDERATIONS FOR INSTALLATIONS

SCENARIO 3: Directional build with one 90-degree sweep (HDPE or PVC)

- ▶ Transition out of Vault A made with ConduitConnect™ coupler
- ▶ Transition to and from sweep made with ConduitConnect coupler
- ▶ Transition into Vault B made with NS Shur-Lock II coupler for ease of installation between two sections of conduit

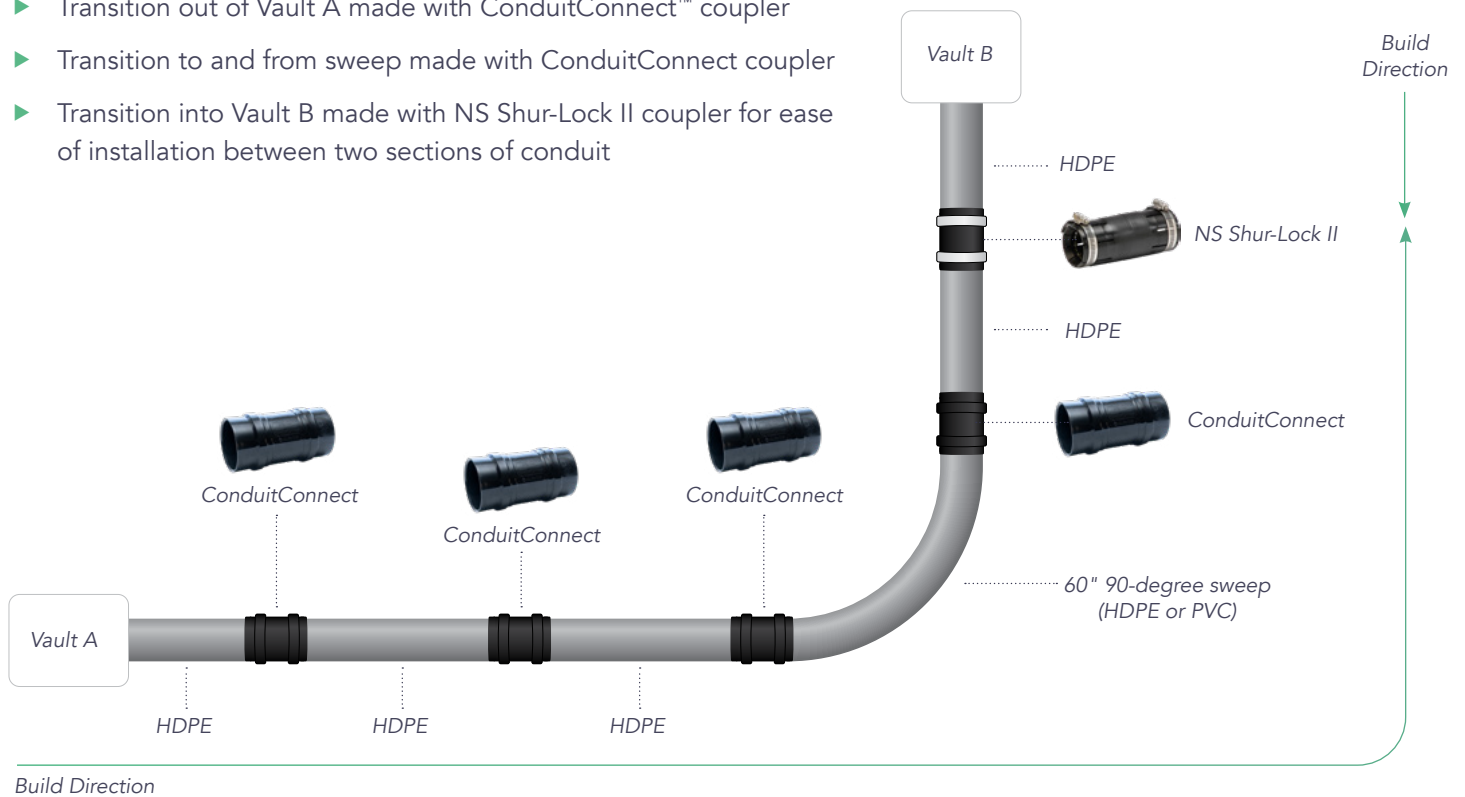

HDPE conduit coupled to a PVC sweep with a ConduitConnect coupler

KEY CONSIDERATIONS FOR INSTALLATIONS

SCENARIO 4: Directional build with one 90-degree sweep (fiberglass or steel)

- ▶ Transition out of Vault A made with ConduitConnect™ coupler
- ▶ Transition to and from sweep made with Shur-Lock II coupler
- ▶ Transition into Vault B made with NS Shur-Lock II coupler for ease of installation between two sections of conduit

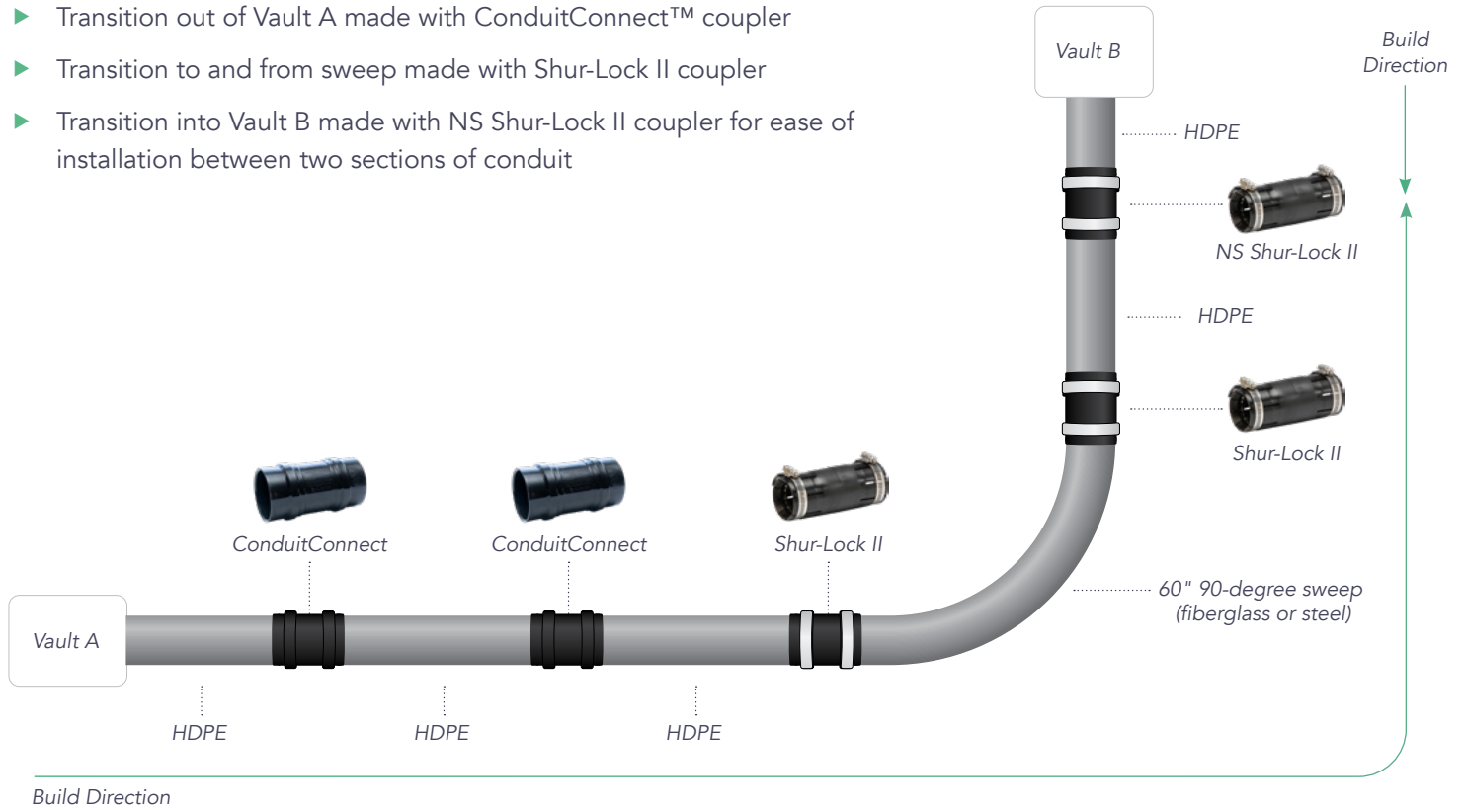

SCENARIO 5: Replacing a damaged HDPE stick in an established duct route

- ▶ Transition to and from new HDPE stick made with NS Shur-Lock II coupler for ease of installation in the middle of run

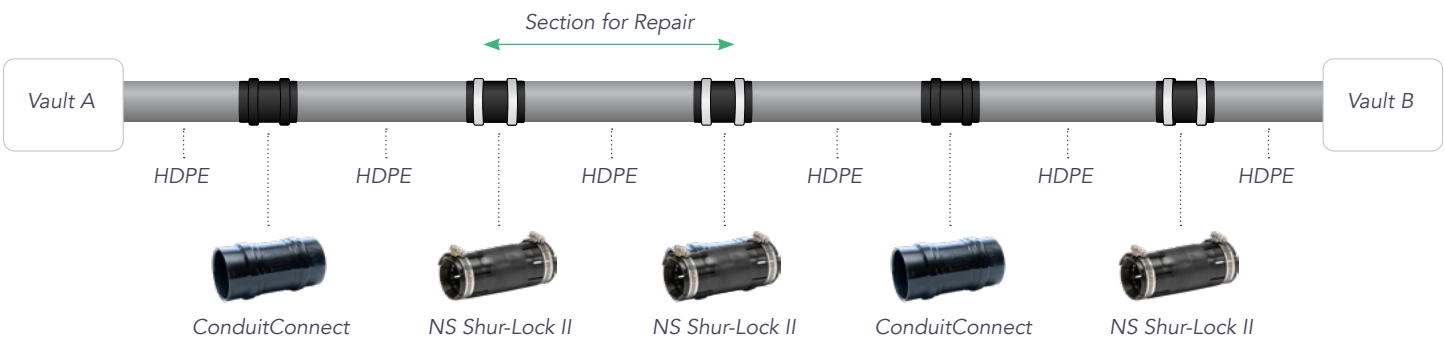

KEY CONSIDERATIONS FOR INSTALLATIONS

Mitigation of Thermal Expansion and Contraction

HDPE is a thermoplastic, which naturally expands and contracts with temperature fluctuations. Once a trench has been backfilled, the surrounding soil will mitigate these effects, but, until then, the impact can be more pronounced. Therefore, if simply backfilling with soil, it is recommended to delay the installation of the last section before the vault (typically 5 to 15') until the full run between vaults can be backfilled in entirety.

Finally, if using spacers to build a duct bank, the HDPE sticks should be able to move freely. This means that, while the spacers themselves should be secured to the ground, HDPE sticks should not be secured with bands or clamps, allowing them to expand and contract with any fluctuations in temperature.

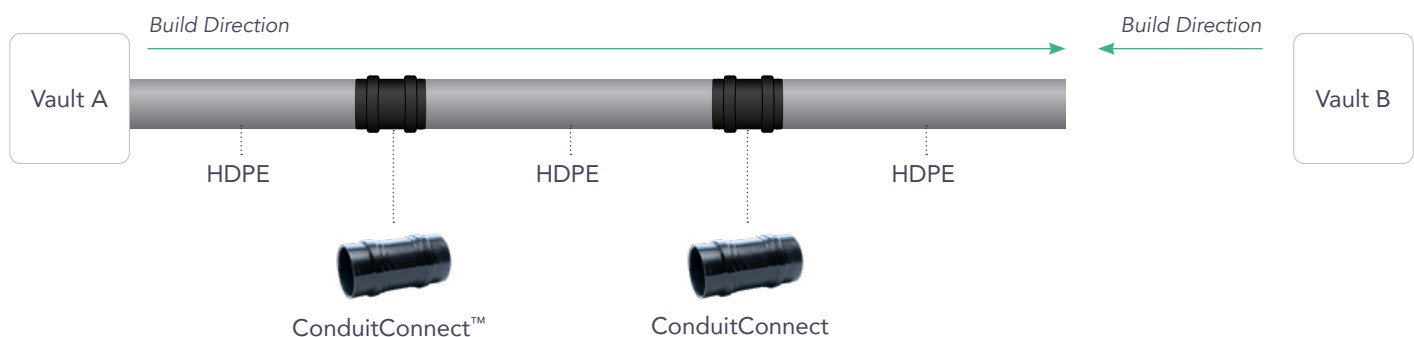

Concrete Encasement Scenarios

If encasing the duct route in concrete, the installation of the last section should be delayed overnight, to allow the conduit to expand and contract with natural temperature cycling. The next day (or later), check that all couplers are secure, then pour concrete up to a few feet before the end of the last stick and leave to cure to allow for expansion and contraction in the conduit during the curing process. After this period, the final section of conduit can be installed and encased in concrete immediately (as depicted, left).

KEY CONSIDERATIONS FOR INSTALLATIONS

Vaults

Duct Termination

Where placement of cables or sub-duct is to take place at a later date, a duct run should be sealed with an expansion plug to prevent ingress of moisture and/or debris. Each plug features an internal eye for securing Bull-Line® Pull Tape and an external eye for easy removal and reuse.



Expansion plug



Expansion plugs installed in a vault



Close up of expansion plugs installed in a vault

Vaults with PVC Inserts

Some vaults, particularly those used in large-scale power applications built with duct banks, are pre-fitted with PVC inserts, which effectively act as couplers to ensure a secure connection. In this scenario, the initial entry and exit of each duct run must be made with PVC conduit (typically 3-5' in length) before transitioning to HDPE.



Duct entry point into a vault with insert



Right-to-left: transition from HDPE sticks to short PVC lengths with NS Shur-Lock Couplers before entry into vault

KEY CONSIDERATIONS FOR INSTALLATIONS

Transitioning To and From PVC for Vault Entry

When building a directional duct bank from one vault with PVC inserts to another, the initial transition from PVC to HDPE conduit should be made with a ConduitConnect™ coupler. In contrast, it is recommended that the transition back to PVC for entry into the second vault be made with a NS Shur-Lock II coupler.

Maneuvering a long run of sticks into a duct entry can be difficult, especially with PVC, which is not as flexible as HDPE. But with the NS Shur-Lock II, the short length of PVC can be installed into the duct entry first. Then, the coupler (free from an internal stop) can be slid over the HDPE duct which can then be aligned more easily with the PVC. Once aligned, the NS Shur-Lock II can simply be slid into place for coupling, then tightened.

This scenario is illustrated below:

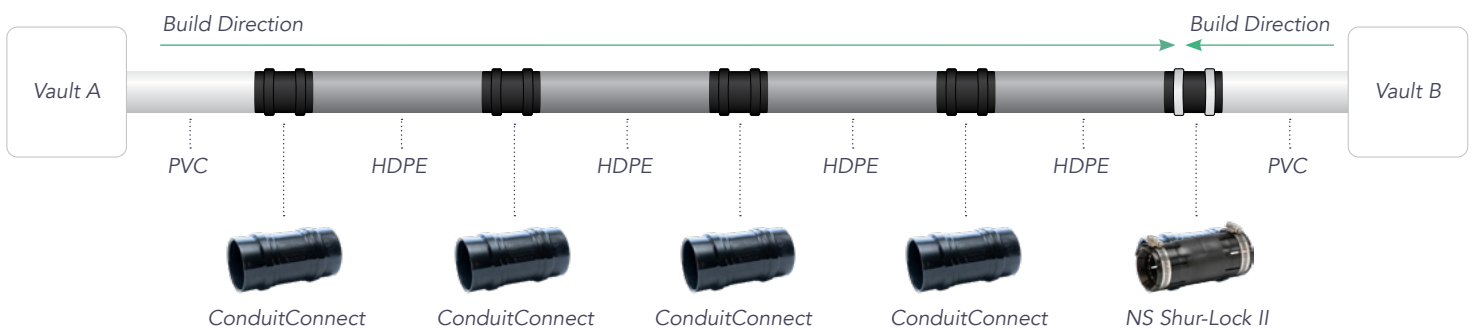

KEY CONSIDERATIONS FOR INSTALLATIONS

Termination at Pad-Mounted Equipment

In power distribution, the transition from underground ducts to pad-mounted equipment (e.g., transformers, switchgear) is typically done via an HDPE sweep or PVC elbow, which routes the cables through a ground sleeve ready for termination. This can be done quickly and simply using the ConduitConnect™ coupler.

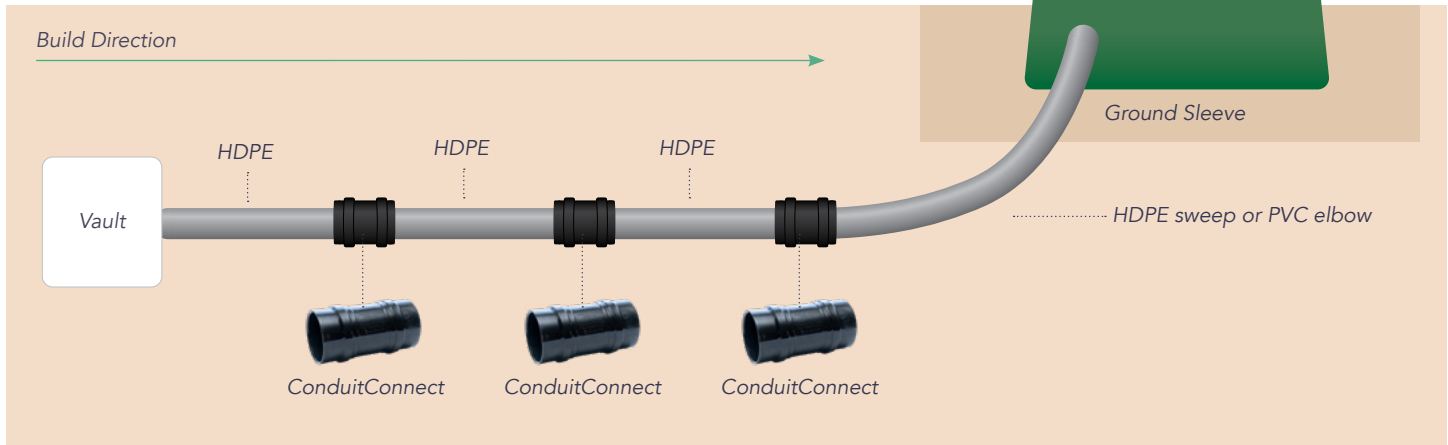

This photo shows the inside of a transformer pad with secondary (600 V) cables entering through a PVC elbow (top left) and primary cables (15-35 kV) entering through red HDPE conduits (bottom right). In this scenario, the red HDPE conduits have an outer diameter (OD) of 2", meaning they are flexible enough to route through the ground sleeve without a sweep or elbow.

PROOFING

Proofing

Before a new duct system is accepted by the infrastructure owner to become operational, its quality and suitability for purpose should be verified via a process called "proofing." This involves pulling a tool known as a "mandrel" through the length of the pathway to ensure it is free from obstruction, debris, and to check conduit ovality.

The benefits of proofing a duct system include:

- ▶ Verification that the route is continuous and without bend radii violations
- ▶ Removal of any foreign objects that may have entered the system
- ▶ Confirmation of proper coupler sealing
- ▶ Validation that there are no restrictions that might affect the future placement of pulling tapes and/or cables via approved air-assisted or pulling methods

Proofing Strategy

Proofing requirements can differ from project-to-project, so it is important to establish a proofing strategy prior to duct installation and provide a written record of proofing results to the infrastructure owner.

Overall strategy may be to proof:

- ▶ Prior to backfill so any issues can be more easily rectified
- ▶ After the route has been backfilled and tamped to determine the quality of the completed product
- ▶ Only a sample of ducts within a duct bank

Any proofing procedures or specifications from the infrastructure owner supersede the recommendations offered by Dura-Line in this document.

PROOFING

Mandrels

Mandrels come in a variety of shapes, constructions, and materials, according to the type of duct system they are to be used in, but they should always be slightly smaller than the inner diameter (ID) of the duct being tested (typically 80% of the ID). When proofing HDPE sticks in duct-bank applications, an aluminum or wooden mandrel is recommended with sufficient length to verify that the angle of any sweeps being used is not too tight.

Alternatively, a flexible foam piston may be used to clear water from a pathway, though this solution may not have the same longevity as the steel or plastic mandrels in hyperscale duct bank applications where the proofing process is likely to be repeated on a large scale.



Clockwise from top

Wooden mandrel

Aluminum mandrel

Flexible foam piston

Proofing Procedure

General steps when testing with a mandrel:

1. Choose an appropriate mandrel for the application and duct conditions
2. If duct does not have an existing pull line, install pull line with a rodder or by injecting pull line through pneumatic means
3. Connect existing pull line to mandrel
4. Connect alternate pull line to opposite end of mandrel
5. Pull mandrel through duct
6. Secure pull line at either end (if required)

PROOFING

Clearing Water or Debris

If during proofing, a duct is found to contain water, soil, and/or other debris, it should be cleared using a wire brush and/or disk-type mandrel, pulled through the conduit in the same manner as the standard proofing procedure outlined previously.

Wire brush mandrels are effective in removing mud from a pathway, especially when it is being flushed with water during the mandrel-testing process. But the brush may bypass some obstructions or travel through flattened sections of duct.

Multi-disc type mandrels are effective in removing both water and mud. The discs are spaced and tapered to allow passage through any tight bends.

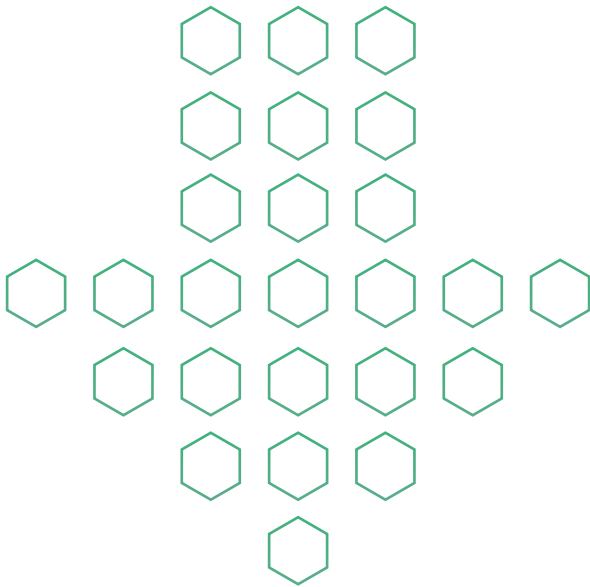

Clockwise from top

Wire brush mandrel

Flexible mandrel with steel discs

Flexible mandrel with plastic discs

More Information

For a more detailed duct proofing procedure, refer to Dura-Line Technical Bulletin: DCEB-03002.

DURA-LINE ACADEMY

Get Field-Ready, Faster.

Dura-Line Academy offers 65+ mini courses on industry products, fiber and power applications, and installation best practices.



HDPE Sticks

For more information on HDPE Sticks, check out the following mini courses (each takes 15 minutes or less to complete):

- ▶ HDPE Stick Installation



- ▶ HDPE vs. PVC



- ▶ Shur-Lock II:
for ODs 3" and larger



Don't have an account?
Create one for free today!



www.duraline.com/academy



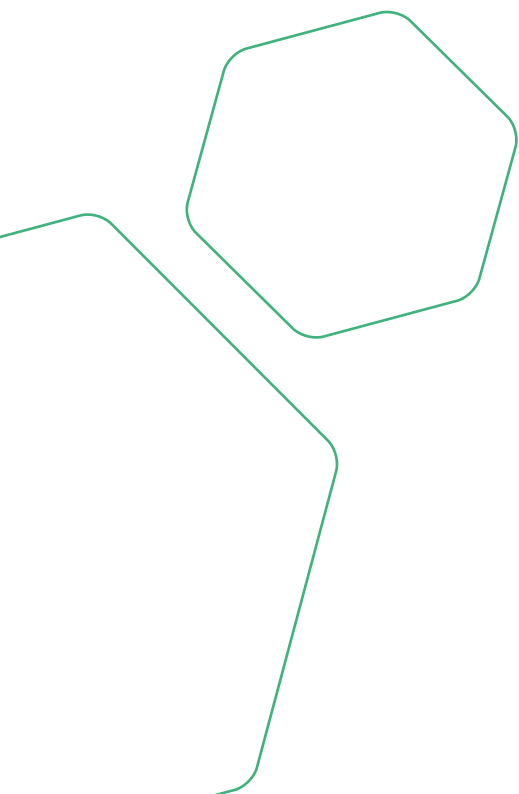

Orbia's Connectivity Solutions business, Dura-Line, is a leading manufacturer and distributor of high-density polyethylene (HDPE) conduit, accessories, and other connectivity solutions for the telecommunications, data center, and power markets. With more than 50 years of experience and a long-standing reputation for the safety, efficiency, and durability of its products, Orbia Dura-Line produces more than 500 million meters of infrastructure annually, forming the physical pathways for fiber and power networks that connect people worldwide.

Contact us:

Phone: (865) 218-3460
Toll Free: (800) 847-7661

e-mail: moreinfo@duraline.com
www.duraline.com

© 2026 Dura-Line. All rights reserved. Reproduction in whole or in part is prohibited without the prior written consent of the copyright owner. No liability will be accepted by the publisher for any consequence of its use. Publication thereof does not convey nor imply any license under trademark or other industrial or intellectual property rights.

